

ASSEMBLY INSTRUCTIONS

GABION FENCE PRAKTIK

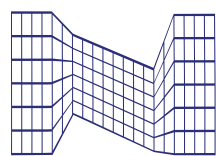
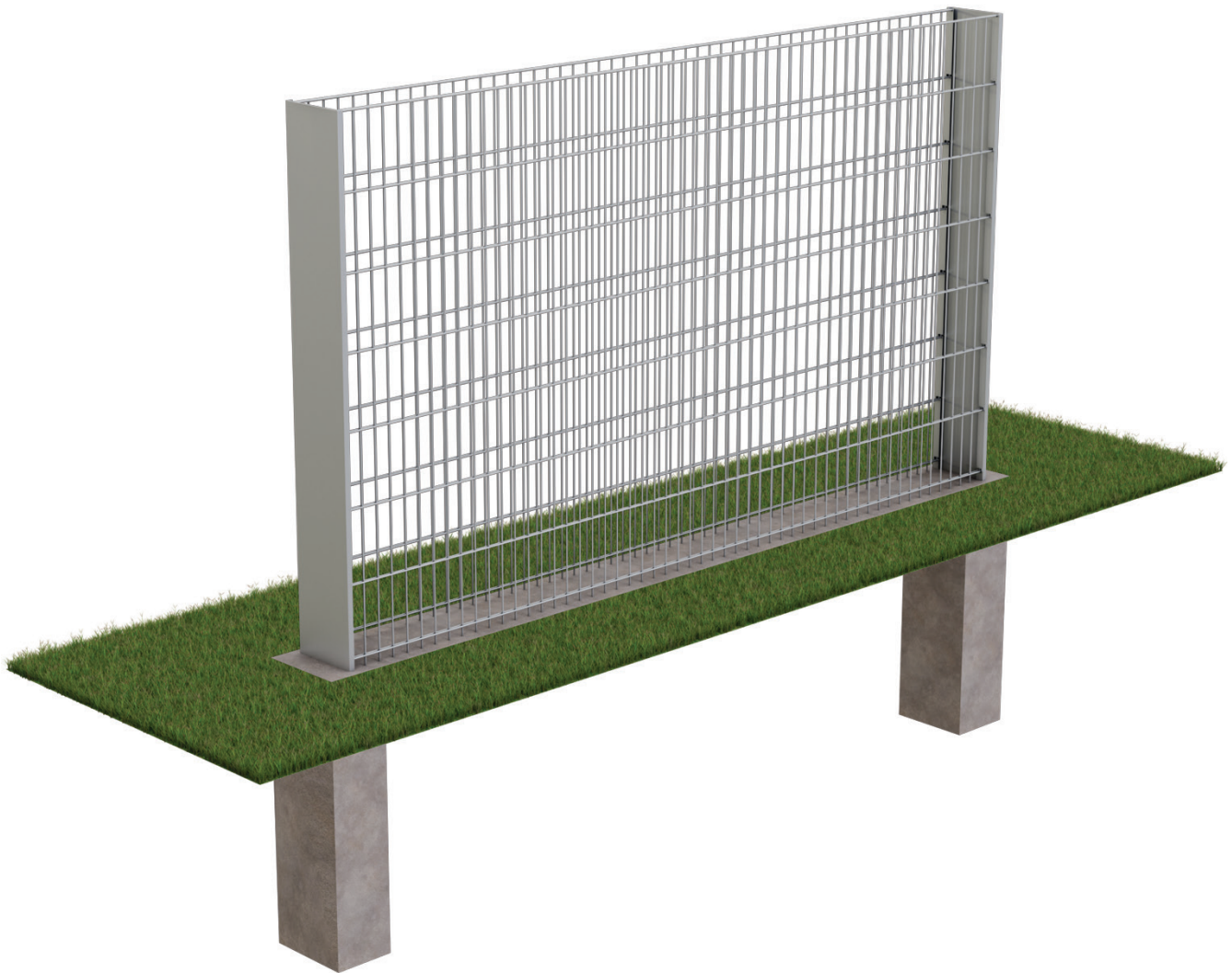

GABION
LEMON

www.gabionlemon.com

All images are illustrative only. All rights reserved to the company Lemon trade, s.r.o.
Use of the catalogue content is possible only with the written consent of the owner.

DESCRIPTION OF GABION FENCE 2D PRAKTIK

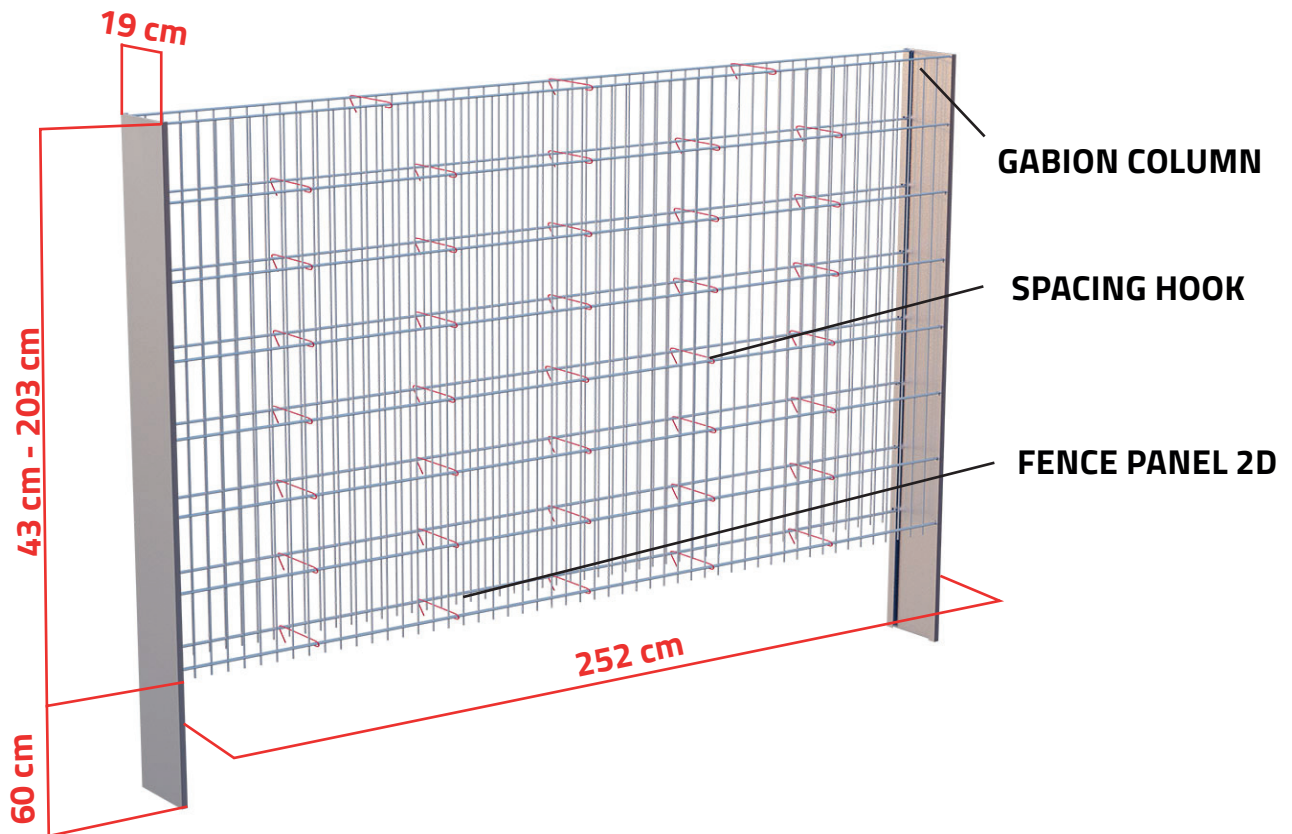

COMPONENTS OF PRAKTIK FENCING



FENCE PANEL 2D

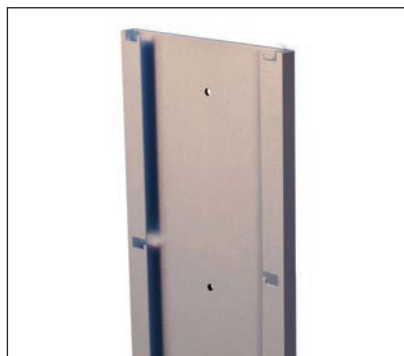

GABION COLUMN

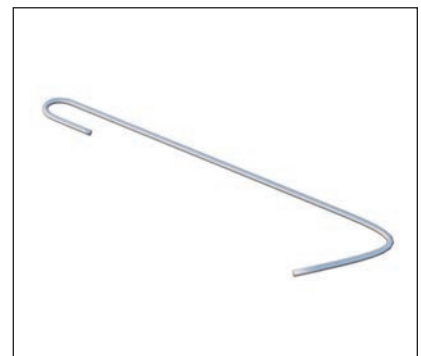

SPACING HOOK (19 CM)

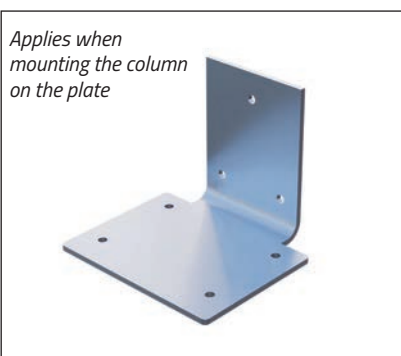
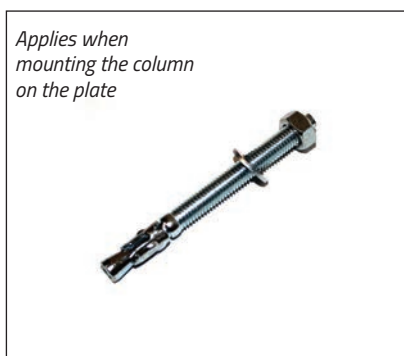

PLATE FOR GABION COLUMN



CONCRETE ANCHOR M8X95/45



M8 SCREW + M8 NUT

TOOLS REQUIRED FOR ASSEMBLY

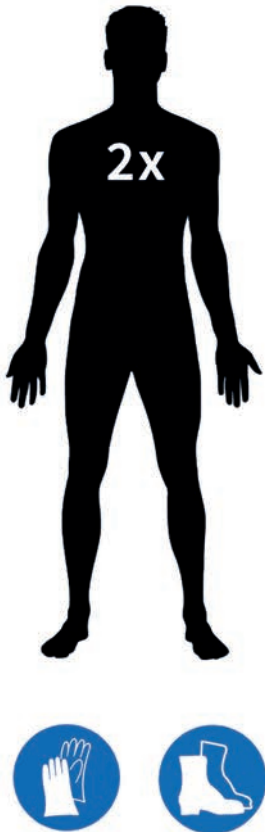

RATCHET



MEASURE



AGGREGATE BUCKET



LIQUID LEVEL

TOOLS FOR DIGGING A PIT



OR



OR



2 VERSIONS OF INSTALLING THE COLUMNS

1. COLUMN IN CONCRETE

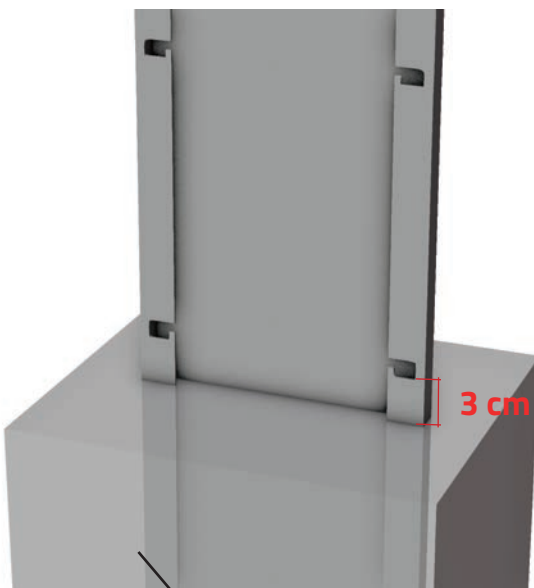

CONCRETE

2. COLUMN ON THE PLATE

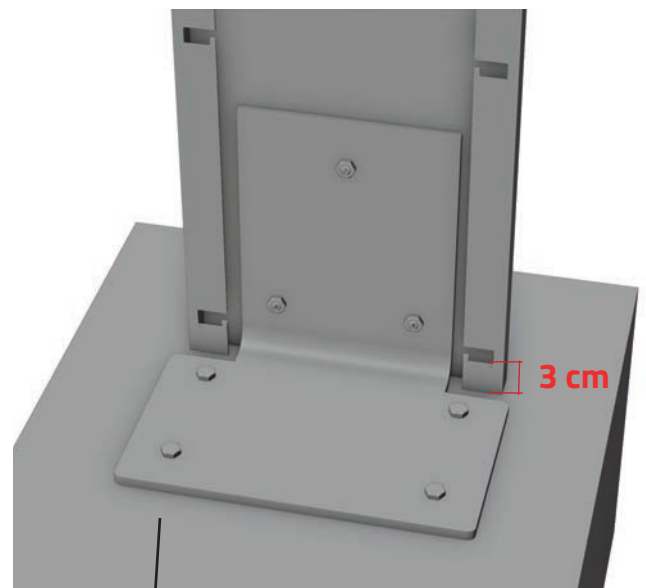

CONCRETE

THE PROCEDURE FOR MOUNTING COLUMNS IN CONCRETE

- 1 First of all, dig the installation pits necessary for setting and concreting the columns. Dig the pits with a spacing of 252 cm (centre of the pit). The depth of the excavation must be at least 60-80 cm, ideally below the frozen depth.

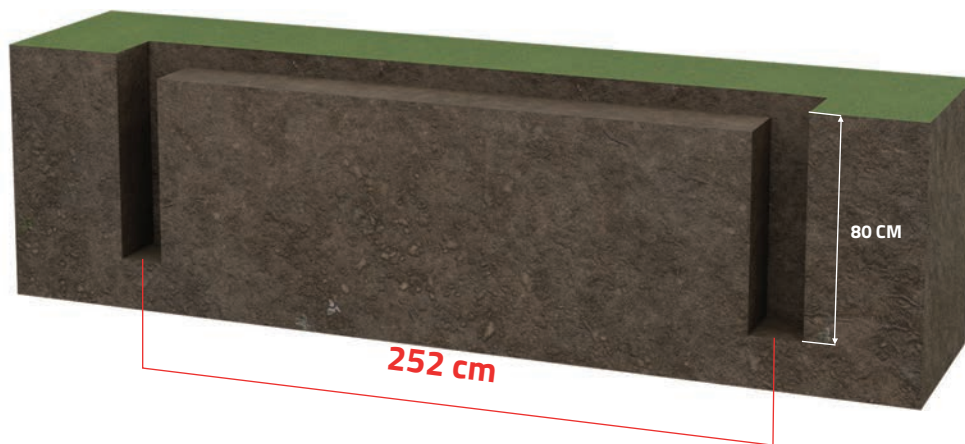

- 2 When you have excavated the pits, place posts in them with a spacing of 252 cm and proceed to the concreting itself. Use semi-dry concrete (dense), not thin, so that the pillars in the pits stand and do not fall. Align the posts with a spirit level. We recommend connecting the two pits with a concrete slab with a minimum width of 25 cm and a thickness of 10 cm, which will be reinforced with steel. This plate will create a solid foundation along the entire length of the fence.

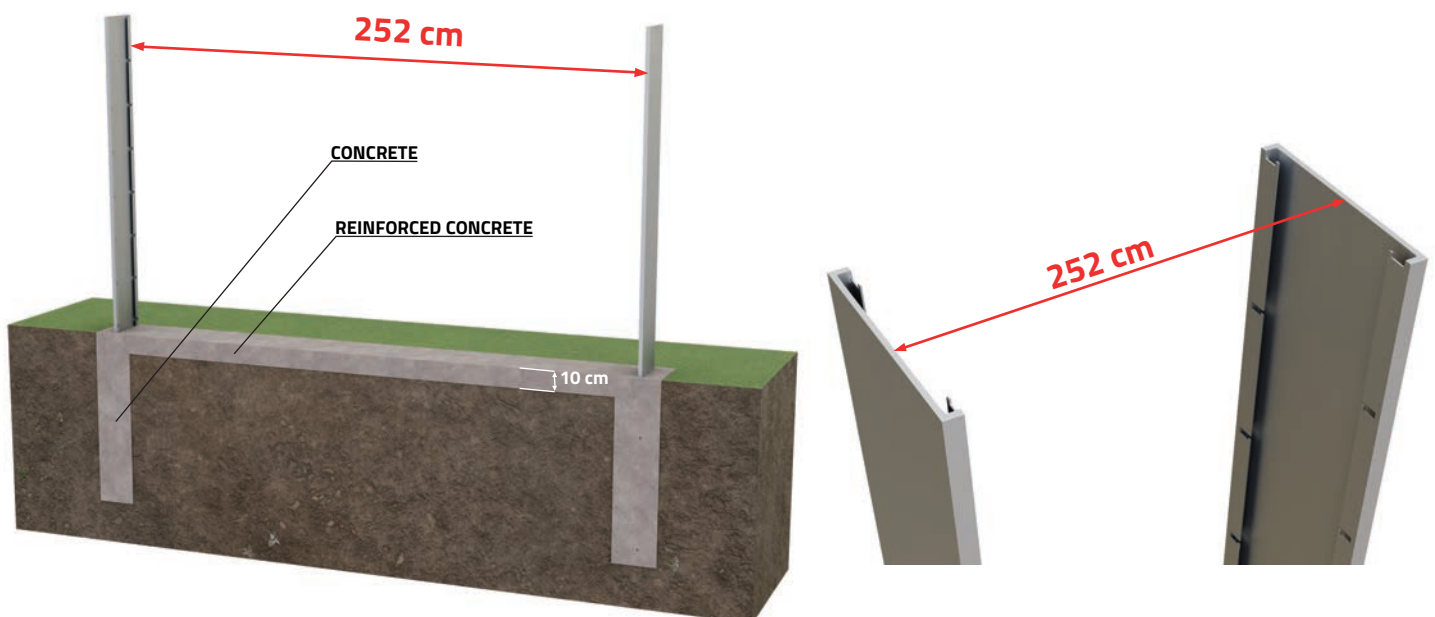

PROCEDURE FOR ASSEMBLING THE COLUMNS ON THE PLATE

If you choose to mount the columns on a slab, the slabs must be anchored to the concrete foundation with chemical anchors.

Attach a post to the plate attached in this way, on which you mark 3 holes according to the holes on the plate. Drill the marked holes on the post with a drill. Subsequently, with the help of screws, connect the column with the plate as in the figure no.1 and no.2.

When connecting several 2.5 m structures into 1 integrated 2D PRAKTIK fence, use two plates for the two connected posts as shown in the figure no. 3 and no. 4.



PROCEDURE FOR INSTALLATION OF 2D PANELS ON COLUMNS

Until the concrete hardens, proceed to the installation of the rear fence 2D panel, thereby achieving the exact desired distance between the posts. Follow the same procedure to install the front 2D panel, thanks to which you will get the final shape of the closed fence.

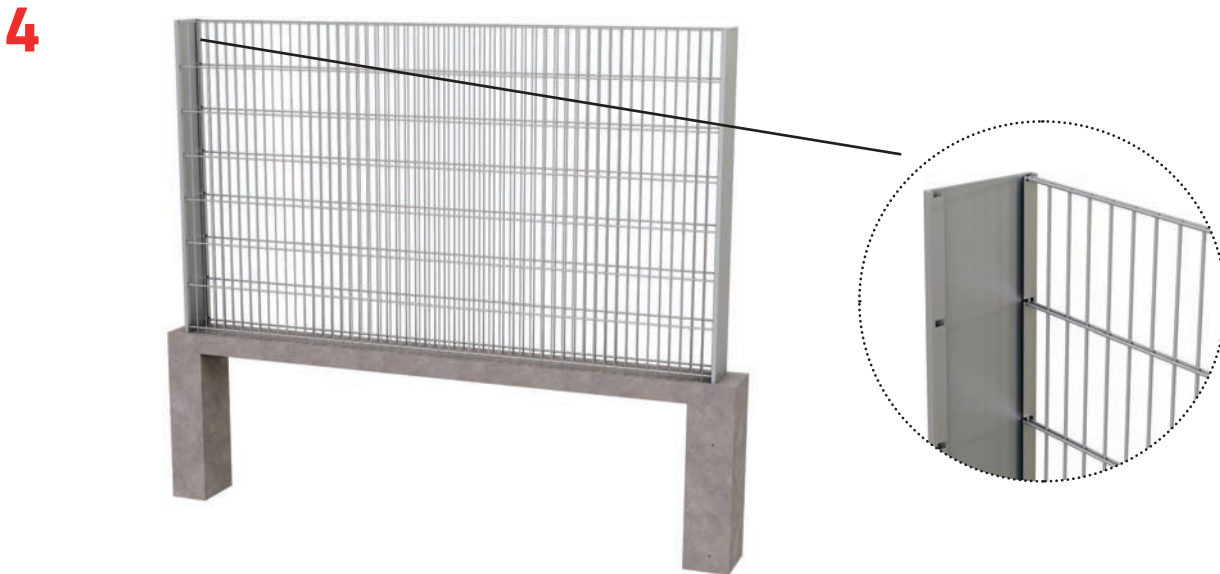

Even before the concrete hardens, level the fence using a spirit level. During the hardening of the concrete (after the panels are installed), it is recommended to fix each column with wooden boards (as shown in the figure) until the concrete has completely hardened.

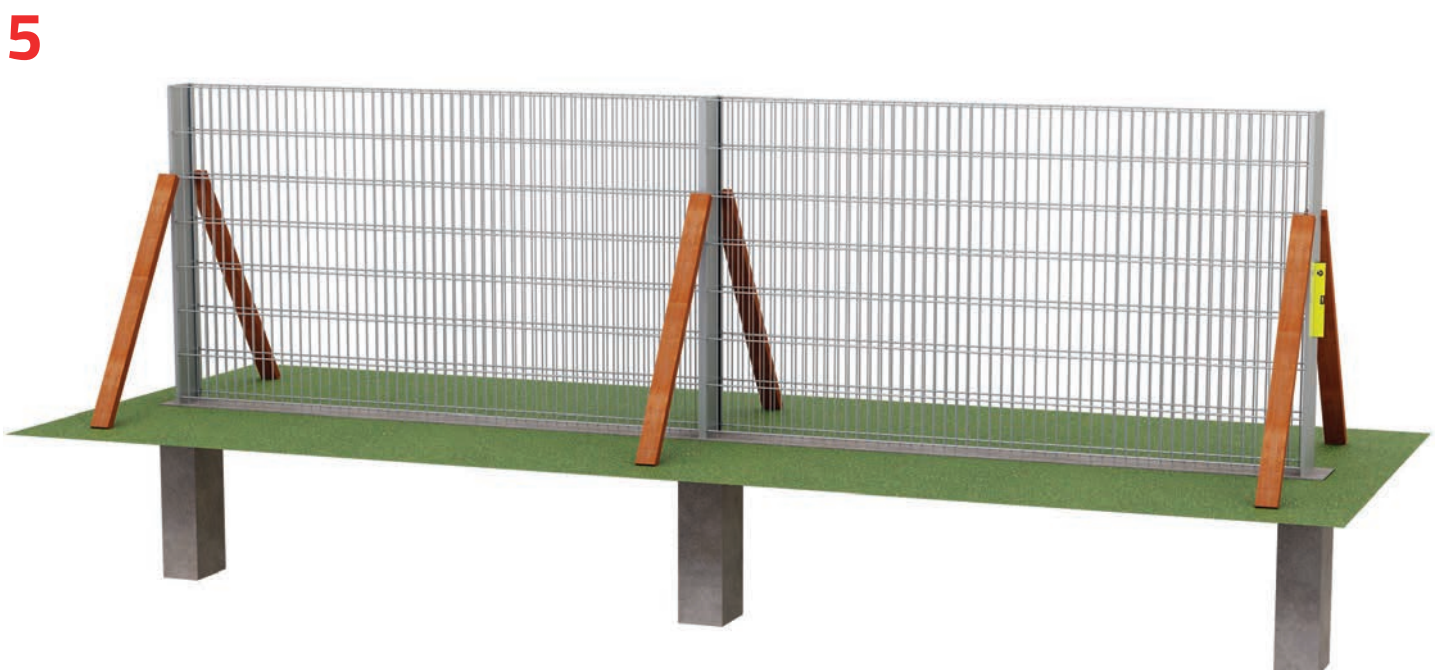

ASSEMBLY OF GABION STRUCTURE LONGER THAN 250 CM

If you are connecting several 2.5 m structures into one complete Praktik gabion fence, proceed in such a way that the posts are screwed together before concreting as shown in figure no. 1.

The posts screwed in this way are then concreted into the ground.

The rest of the assembly procedure (placing the 2D panels on the posts as in figure no. 2) is the same as the assembly procedure of the 2.5 m Praktik fence on page 5.

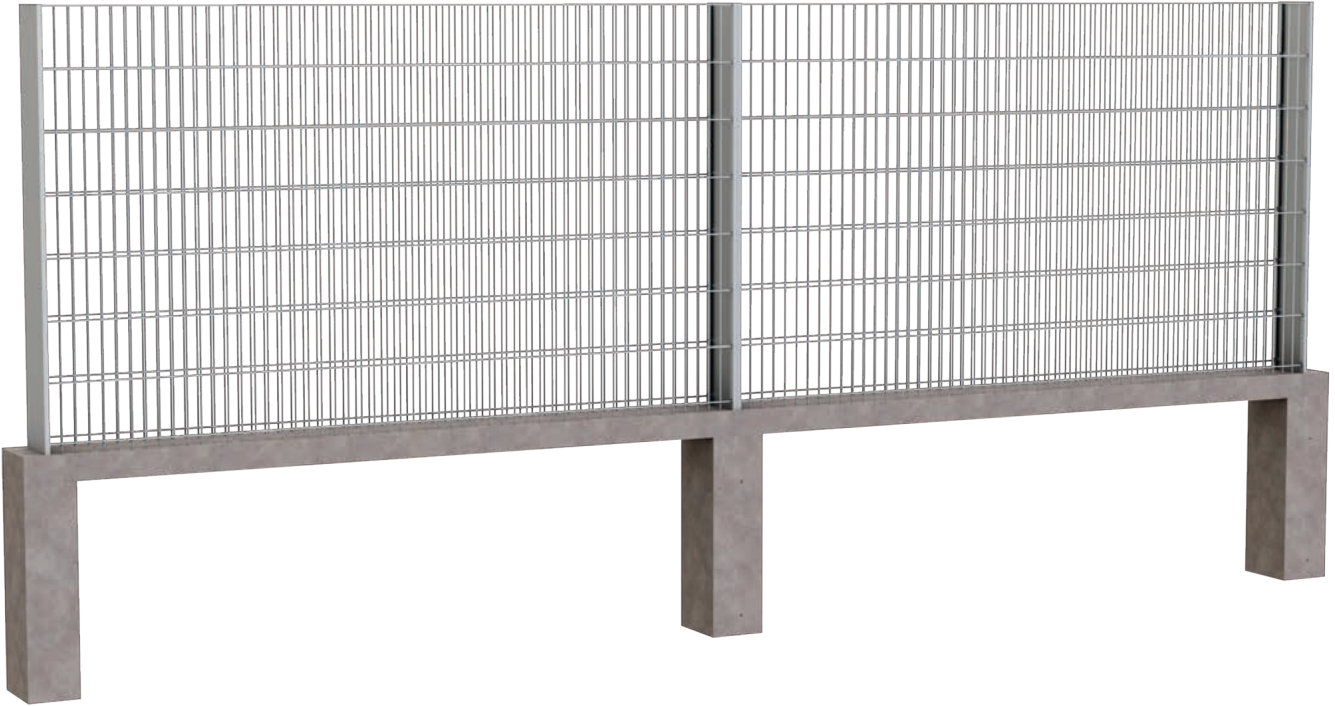

Gabion posts are connected with screws into pre-drilled holes (Fig. 1). For screwing, it is enough to use every 3rd or 4th hole (depending on the height of the column).

The screws are included in the package.

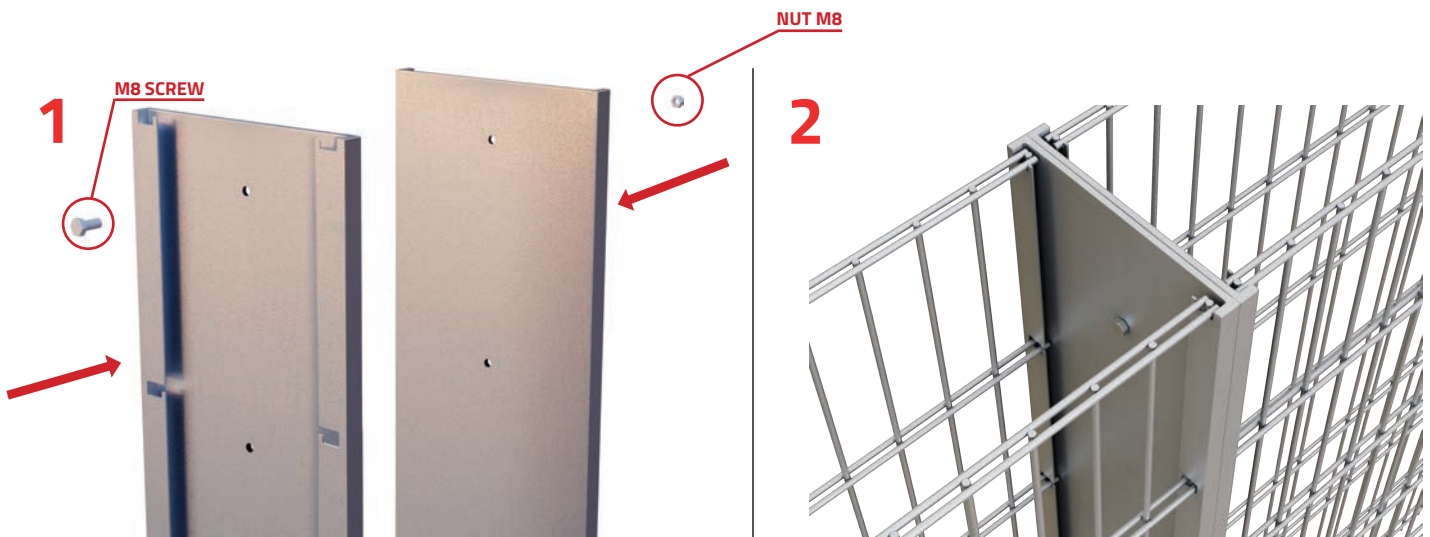

TWO 2D PANEL INSTALLING OPTIONS

The 2D panels used for assembling the 2D Praktik fence system are always finished on one side without spikes and on the opposite side they are finished with protruding spikes 3 cm long. For this reason, 2D panels can be mounted on posts in two ways. It is up to the customer which method he chooses during assembly.

1

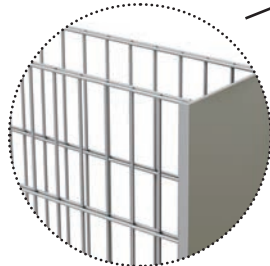
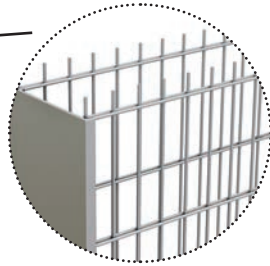

2



Spikes up - figure 1
Spikes down - figure 2

3

If you choose option 1 (setting with spikes up), there will be a 3 cm gap between the concrete base and the fence panel, which may cause the fence panels to bend when filled with stone. For this reason, it is necessary to base the fence panels before filling them with stone as in figure no. 3. After filling with stone, remove the pad.



3 VERSIONS OF CORNER CONNECTION OF THE FENCE 2D PRAKTIK

1 CLOSED CORNER

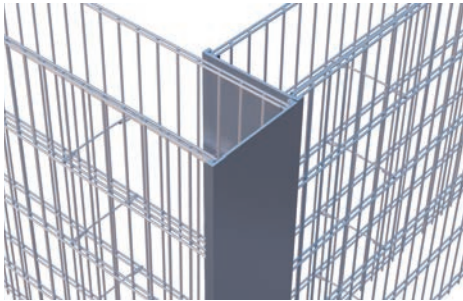

2 OPEN CORNER

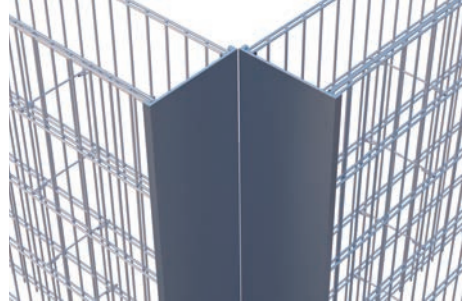

3 SYMMETRICAL CORNER



CORRECT ARRANGEMENT OF MOUNTING HOOKS

Mounting distance hooks are always part of the Praktik gabion fence package. For the correct and perfect final appearance of the fence, it is very important to observe the exact number as well as the regular spacing in each row between the individual hooks.

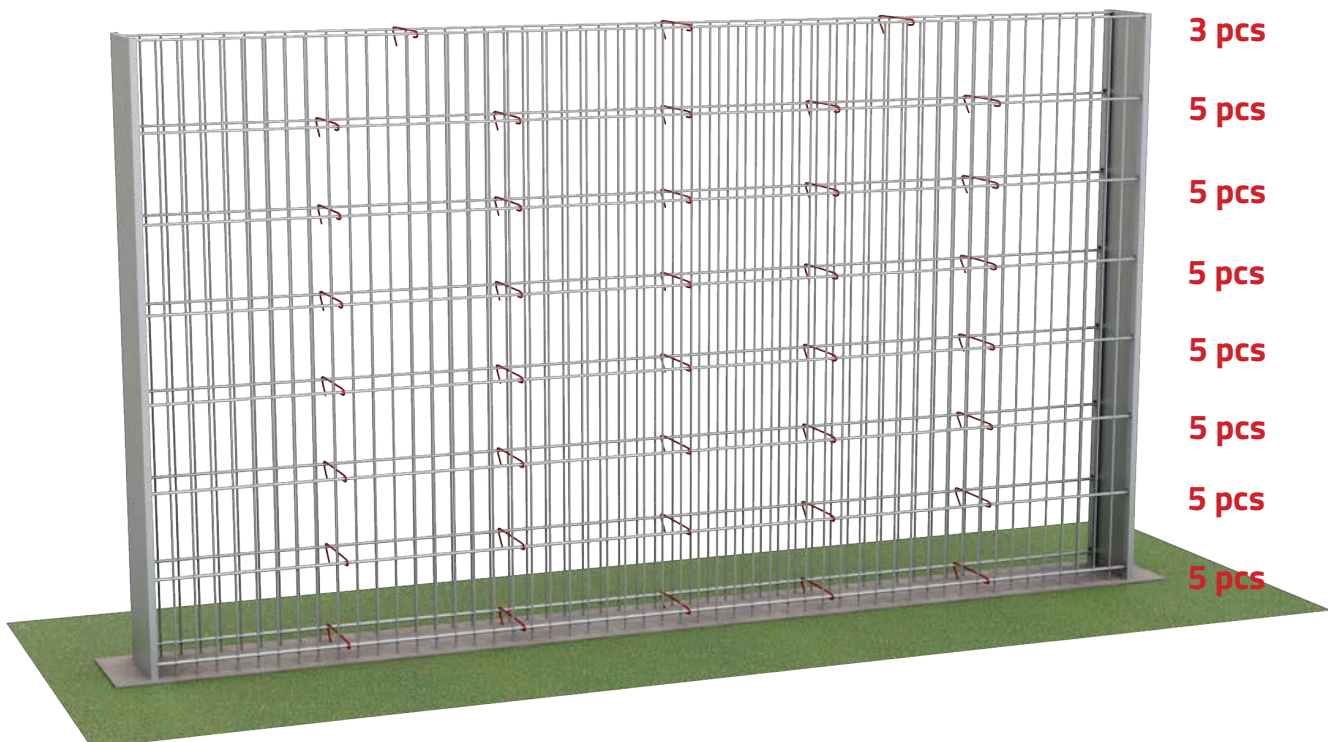

PROCEDURE FOR FILLING THE FENCE WITH AGGREGATES

1



2



3



4



5



6



7



8



THE MOST COMMON MISTAKES DURING ASSEMBLY

1. Preparation of the background

The first and often repeated mistake is an insufficiently levelled and insufficiently compacted base on which the gabion fence will stand. With this error, there is a risk of deviation of the fence from the axis and total deformation of the fence.

2. Plates

If you mount the fence on a plate (and not in the ground) with a height of up to 160 cm, you can use one plate for two posts connected at the back, for which you just need to use the steel anchors that are included in the package. However, if you mount the fence on a plate with a height of 180cm or 200cm, it is necessary to use two plates for two posts connected at the back. To anchor them to the concrete foundation, it is necessary to use only chemical anchors (not included in the package). When using chemical anchors, it is very important to thoroughly blow out the drilled holes from dust and residues after drilling.

3. Installation of columns

Another mistake is when the columns are not concreted deep enough. The correct depth is the so-called frost-free depth, where the soil no longer freezes, preferably 80 cm below the ground surface. For the installation of gabion posts, it is therefore necessary to concrete pits to a depth of 80 cm (60 + 20 cm gravel bed) so that the fence does not collapse over time.

4. Installation of fence panels

If it is necessary to shorten the fence panels to the required size, it is important to use exclusively lever pliers and not an electric flexi sander.

A very important step in the construction of the Praktik gabion fence is its fixation during the hardening of the concrete, therefore it is recommended to fasten each fence panel to the post using wooden boards after the installation of the panels until the concrete has completely hardened. If you choose to install fence panels with the spikes up, a 3 cm gap will be created between the concrete base and the fence panel, which can cause the fence to bend. For this reason, it is necessary to install the fence panels before filling them with stone as shown in fig. 7.

5. Mounting accessories

The correct placement and number of spacer hooks is the key to the final design of the gabion fence. When sprinkling stone into the gabions, you must be especially careful not to cause the spacer hooks to click out, so the hooks must be placed gradually in layers.

6. Choosing the right stone

It is very important that clean quarry stone is used as a gabion filler, without small impurities such as sand, mud or clay, which are washed away by rain over time and can cause deformation of the gabion fence. One of the last mistakes is the use of too small a fraction of the filler stone, which causes it to fall out through the mesh of the fence walls. The recommended size is at least 63-125 mm.



LEMON trade, s.r.o.
Ul. Družstevná 849
Nižná 02743
Slovensko



+421 948 629 850



shop@gabionylemon.com



www.gabionylemon.com